

ELEVATE

USB-C Charging Cart

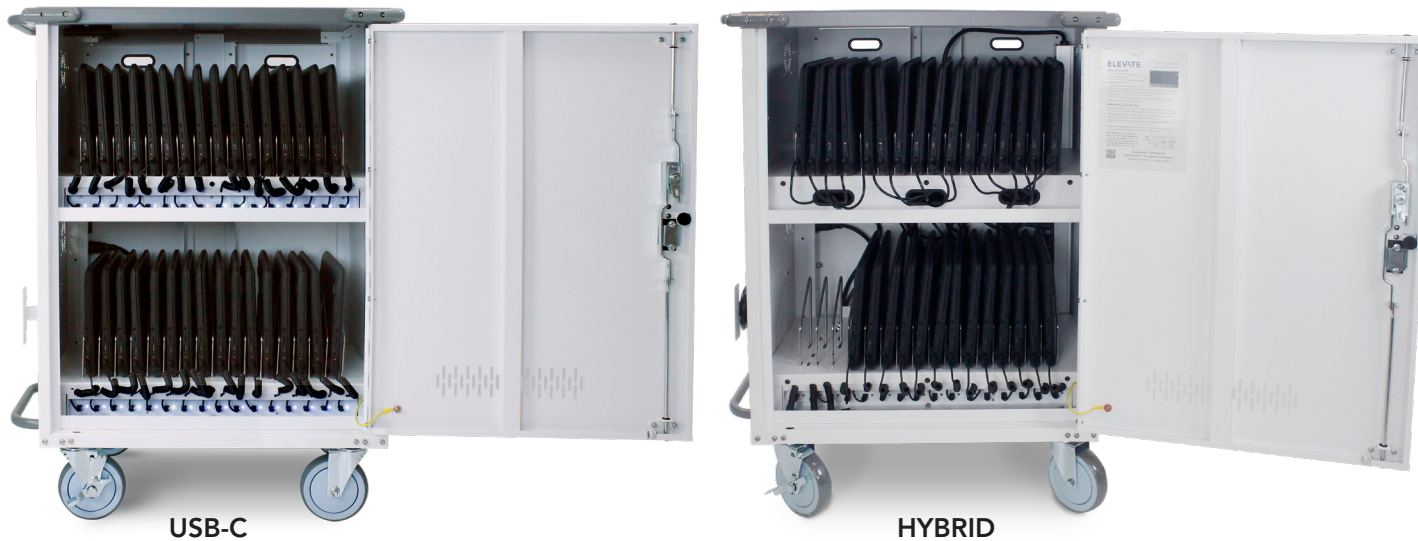











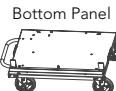
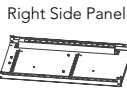
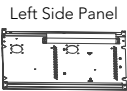
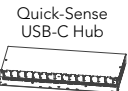

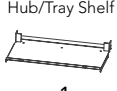
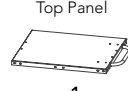

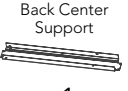
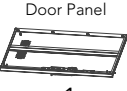
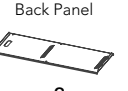
MC-6XXX Assembly and User Manual

Version B

For a copy of the most up-to-date manual, please contact a JAR Systems representative or visit:

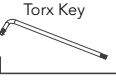
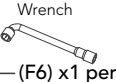
[JAR-Systems.com/Support](https://www.jar-systems.com/Support)

Cart Assembly Instructions

Components					
 Bottom Panel x1	 Right Side Panel x1	 Left Side Panel x1	 Quick-Sense USB-C Hub x2 (optional)		
 Hub/Tray Lid x2	 Hub/Tray Shelf x1	 Top Panel x1	 Top Panel Corner Bumper x4		
 Back Center Support x1	 Door Panel x1	 Back Panel x2	 Power Cord Bracket x2	 Bay Divider x34	
 Screw and Washer (A1) x26	 Screw (B2) x16	 Nut (C3) x12	 Screw and Washer (D4) x14		
 Torx Key (F6) x1 per tool	 Wrench (E5)	 Phillip Bit (G7)	 Drill Tap Bit (H8)	 Cable Clip (G7, H8)	 Misc. Extra

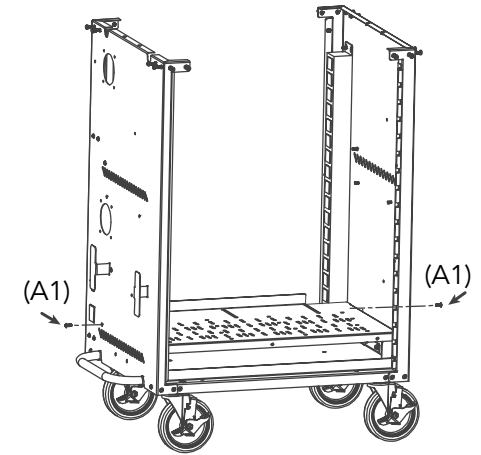
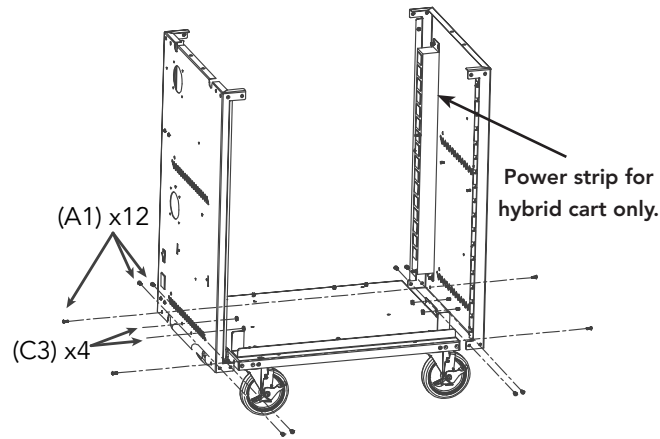

- 1: Attach both side panels to the bottom of the cart. Position the studs in the side panel into the tabs in the base and hand tighten 2 nuts (C3) on each side with the 8mm wrench (E5). **Do not use a power tool to tighten nuts on any step.** Use 3 screws and 3 washers (A1) in each corner.
- 2: Install the hub/tray lid for the bottom shelf using 1 screw and 1 washer (A1) on each side.

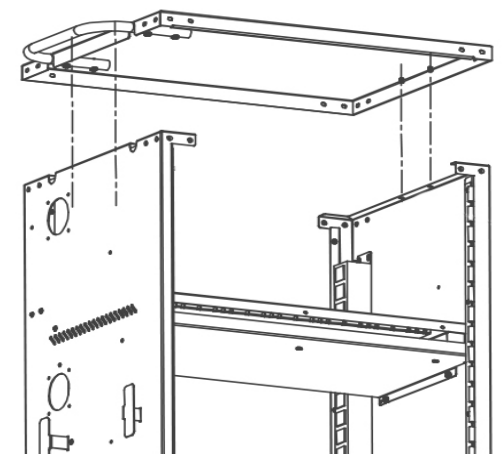
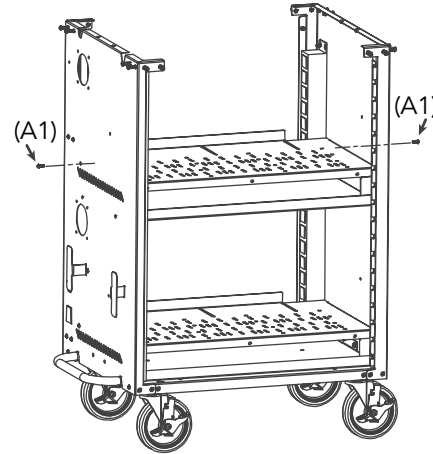
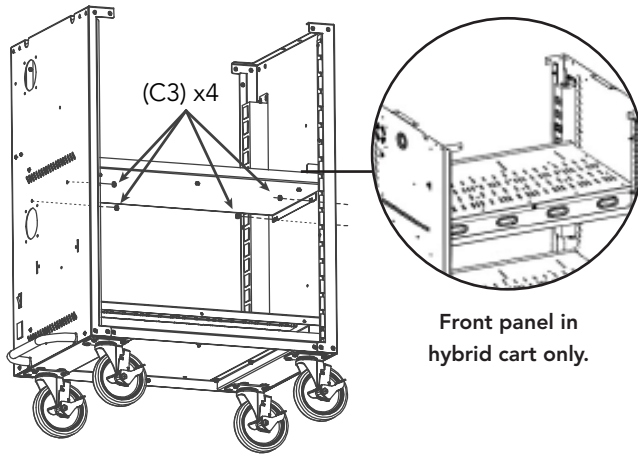

- 3: Install the upper hub/tray shelf. Position over the studs in the side panels and hand tighten 4 nuts (C3) with the 8mm box wrench (E5).
- 4: Install the hub/tray lid for the top shelf using 1 screw and 1 washer (A1) on each side.
- 5: Align the top panel of the cart with the side panels and position it in place. **Do not secure the top during this step.** The top will be secured in step 7.

Hybrid Carts Only: The upper tray shelf features a grommated front panel in hybrid carts only.

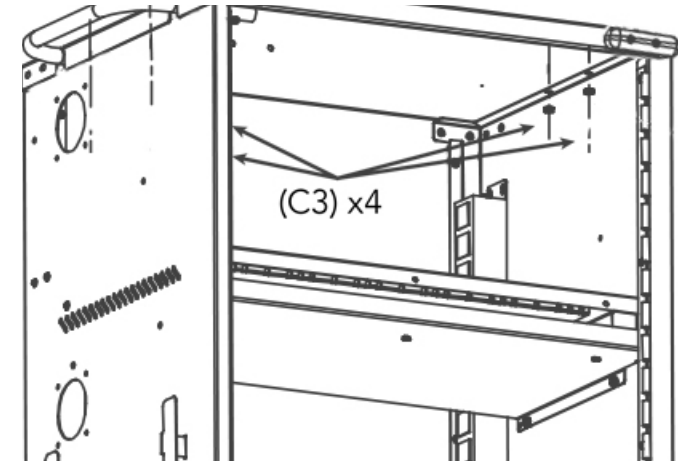
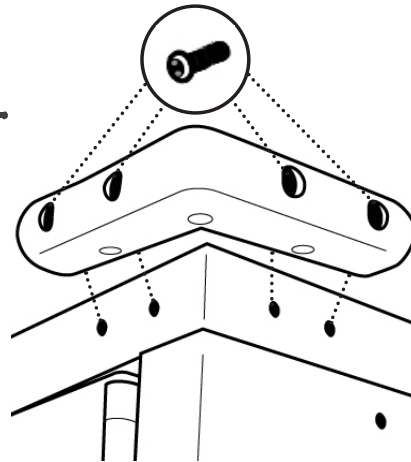
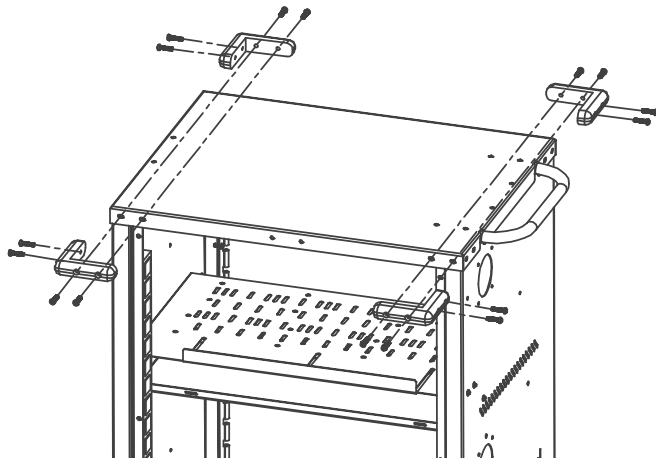

6: Locate the holes on each corner of the top panel for the gray rubber bumpers. With the included drill tap bit (E5), drill through the holes to ensure the screw goes in securely. Place a bumper to each corner of the cart's top and secure in place using 4 screws (B2). The bumpers have a top and bottom side to them. The side with the circle marks should be facing down. To allow for the cart to be squared in a later step, **do not fully tighten the screws during this step.**

7: Using the 8mm wrench (E5), hand tighten 2 nuts (C3) on both sides of the top panel inside of the cart.

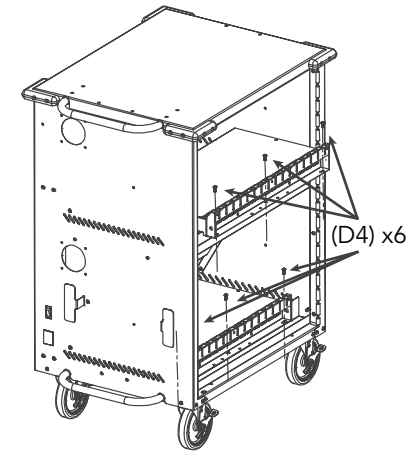
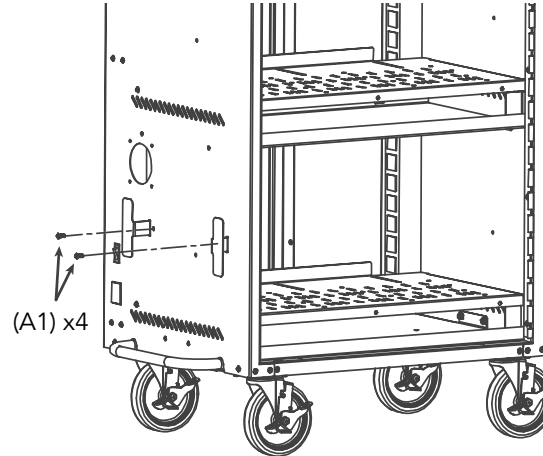
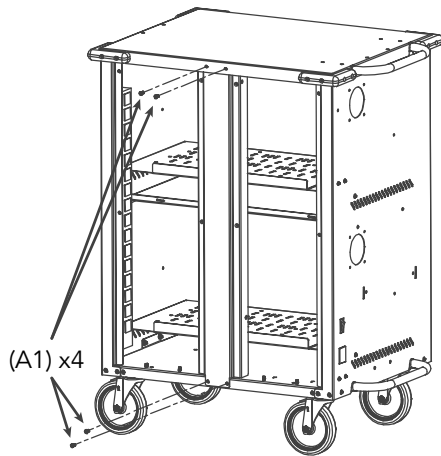

8: Attach the rear center support to the inside of the top panel and the outside of the bottom panel on the rear of the cart using 2 screws with 2 washers (A1) on each end. To allow for the cart to be squared in a later step, **do not fully tighten the screws during this step.**

9: Attach the brackets for wrapping the power cable to the cart's left side panel using 1 screw and 1 washer (A1) on each.

10: Insert the USB-C Quick-Sense hubs, one on the bottom of the cart and one on the hub/tray shelf. Line up the 3 holes on the front of each hub with the holes on the cart and secure with 3 screws and 3 washers (D4).

Hybrid Carts Only: Install the single USB-C Quick-Sense hub on the bottom shelf.

Cart Assembly Instructions

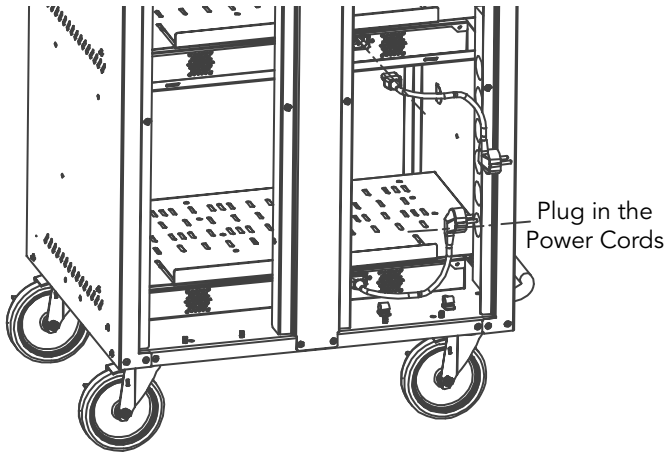

11: Connect the USB-C Quick-Sense hubs' power cords into the back of the hub and the 4-outlet power supply on the side panel.

Hybrid Carts Only: Plug the 16-outlet power strip into the 4-outlet power supply.

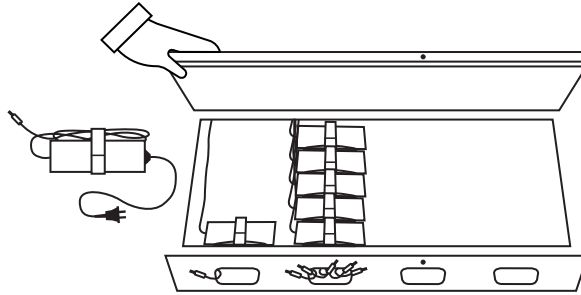

12: Hybrid Carts Only: If installing the AC adapter cables at the same time as the cart assembly, installing after step 11 provides the most unimpeded workflow. See page 6 for cable management instructions. The charging cables can still be easily installed after the cart is fully assembled.

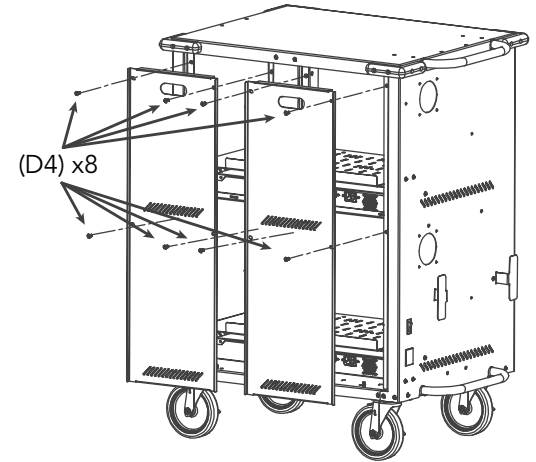

13: Attach both of the back panels to the cart using 8 short screws with 8 plastic washers (D4). To allow for the cart to be squared in a later step, do not fully tighten the screws during this step. Do not use a power tool.

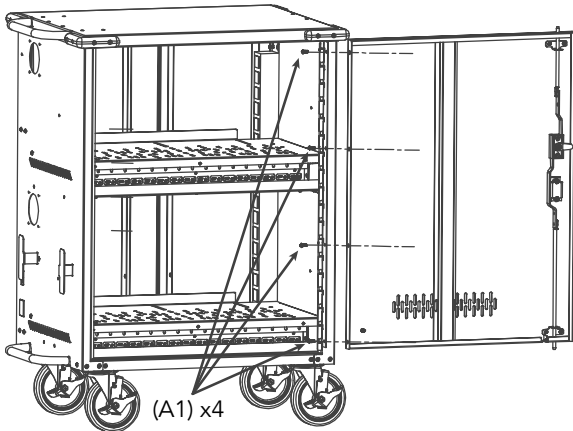

14: Attach the door to the hinge on the right side panel with 4 screws and 4 washers (A1). Insert the Torx key (E5) through one of the screw holes when the hinge and door is lined up to help hold it in place. Remove the key once the first 3 screws are inserted. Make sure that the door is square and opens/closes without striking the frame.

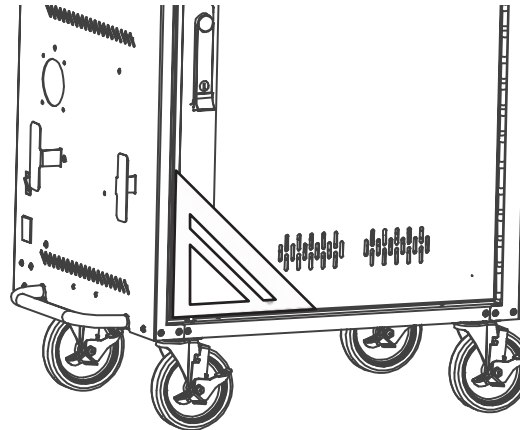

15: Check the cart square by placing a rafter square in the bottom corner of the door frame or use the door as a guide. Once it is squared up, fully tighten all the screws and nuts on the cart.

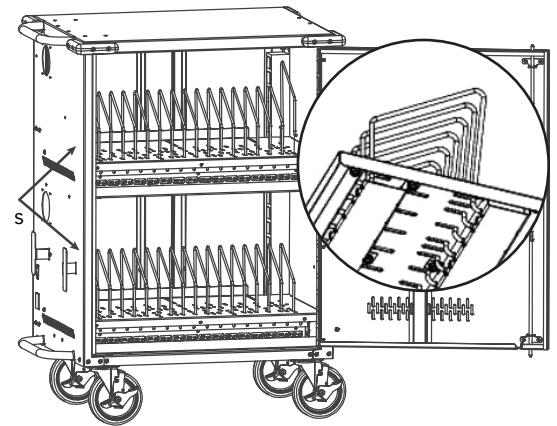

16: Insert the metal device bay dividers into the hub/tray lids. **See diagram on page 5.**

Using the Cart

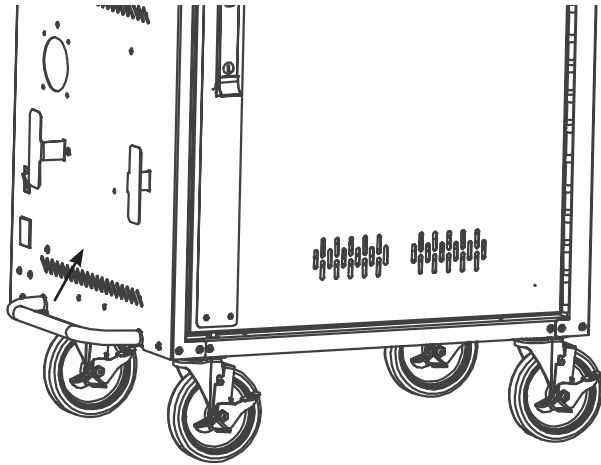

17: Plug in the external power cord into the cart and to a power source. The switch on the side of the cart and the USB-C hub(s) inside should illuminate. If they do not, check all power connections and try flipping the switch. Disconnect from the wall outlet and wrap the power cable around the brackets for transportation.

- Plug the power cable into a standard 15A outlet. Be sure that the power switch on the side of the cart is in the ON position. LEDs will illuminate white to indicate the cart is connected to a power source.
- Power down devices, then connect them to the USB-C charging cables.
- You may hear a clicking sound, and the LED lights will change color according to the power draw of the attached devices.
- The system will automatically limit power consumption by turning some of the USB-C ports off temporarily. Refer to the device itself for the level of charge.
- The devices will charge as quickly and evenly as possible, up to 65W, without drawing too much power.
- Devices that do not feature a USB-C charging port can be charged using USB-C emulator cables. (Not Included, contact JAR Systems for more info)

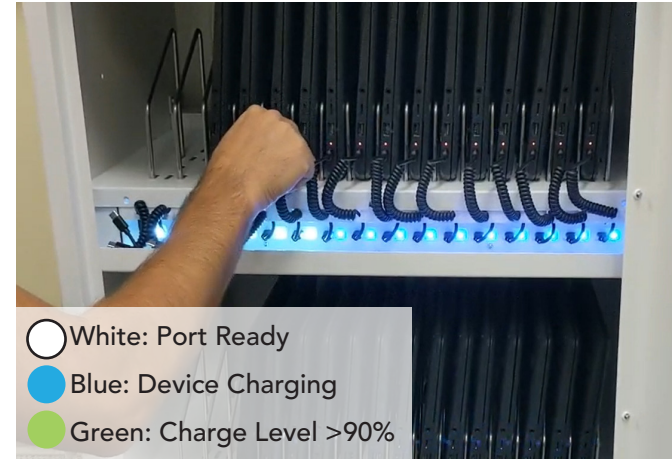

Installing Device Bay Dividers

Elevate carts feature adjustable device bays with multiple configuration options. This means that not every slot in the tray will have a divider in it and there may be extra, unused dividers at the end of the assembly process depending on which hole pattern is used. Use the guides below to determine which hole pattern to use.

To install the dividers, simply place the tall side of the divider into the rear slot first, then push in and down to get the other side into the front slot.

32 DEVICE PATTERN

Best for devices up to 1" wide.

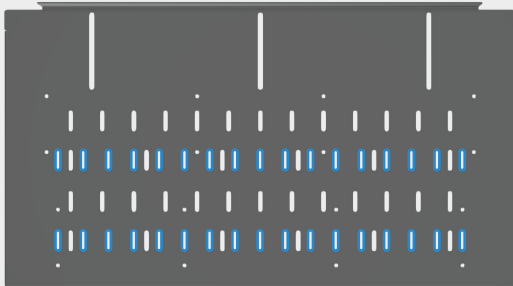

24 DEVICE PATTERN

Best for devices up to 1.25" wide.

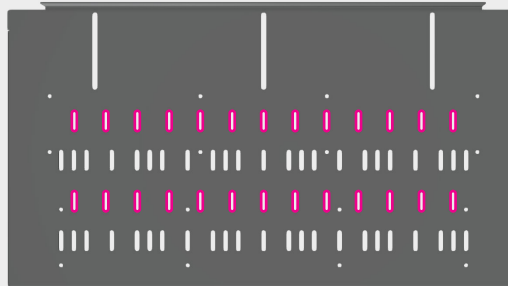

20 DEVICE PATTERN

Best for devices up to 1.5" wide.

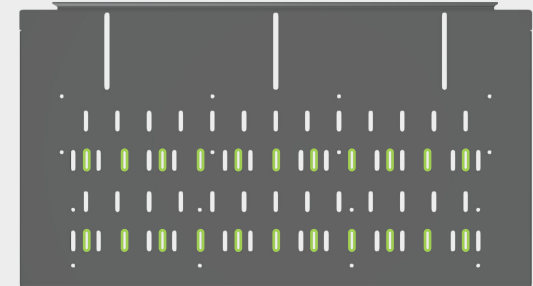

Installing Charging Cables and Adapters (For Hybrid Carts Only)

1: Remove the security screw using the provided Torx key (E5) from the center of the shelf (A) and temporarily place it in the side of the cart (B) to hold the tray open during the wiring process.

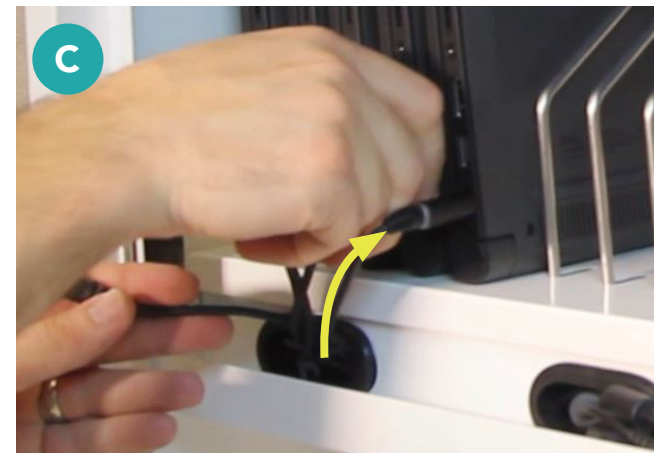
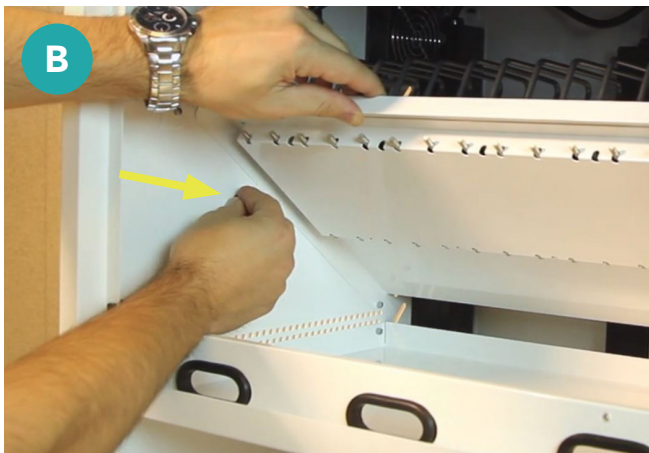

2: Determine the length of cable that is needed to reach from inside the tray to the devices (C).

3: Determine the best method of arranging the cables that come with your device (figures D, E, F below). Use of cable clips (F6, G7) is optional for any configuration.

AC ADAPTERS FRONT TO BACK

Best for some wider adapters.

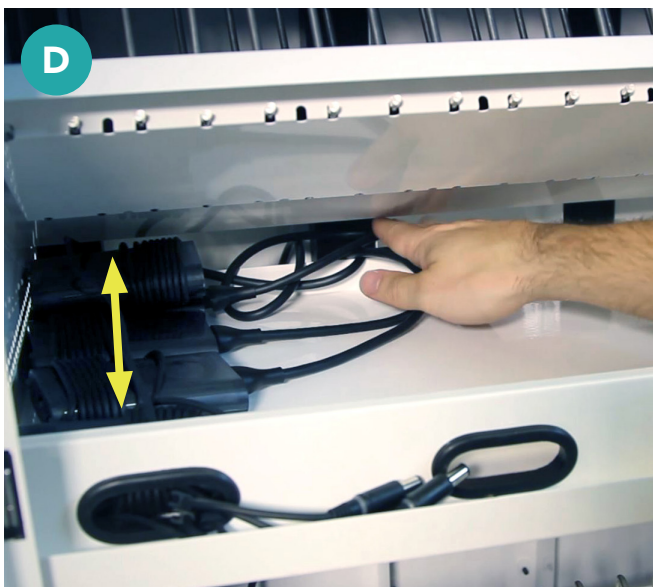

AC ADAPTERS LEFT TO RIGHT

Best for some narrower adapters.

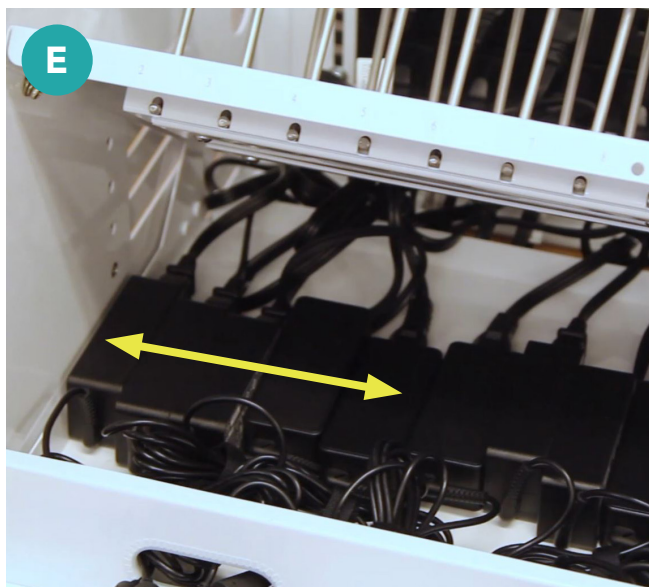

TABLET (NO AC ADAPTER)

Use provided clips beneath shelf to secure cables in groups of 5-6.

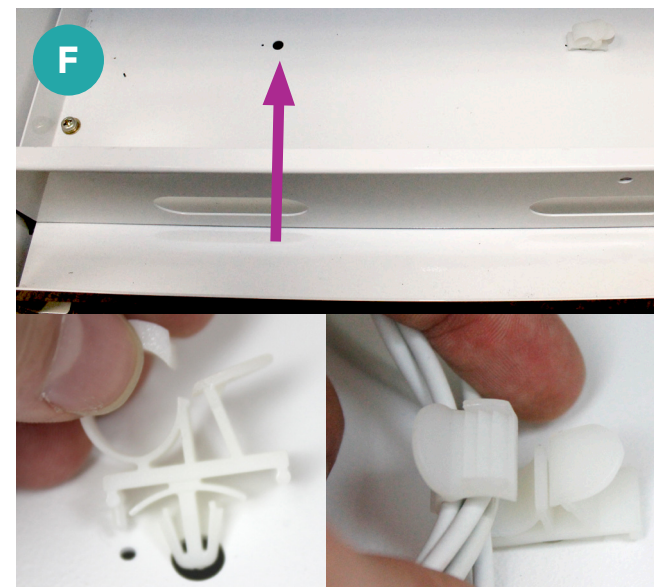

4: Arrange adapters in decided configuration, leaving just enough cable length sticking out of the port to plug in the devices.

TIPS:

Adapters can often be installed as they come bundled in the box. For example, the adapter in figure (G) comes with the cable wrapped around the adapter and it works out nicely when installed in that condition. If the cables are not bundled at all, twist ties or Velcro ties may be helpful.

If the devices have particularly large AC adapters (approximately 5" x 2" x 1.25") the adapters will fit more snugly in the tray. In this case it may be best to arrange the majority of the adapters as far back in the tray as possible from left to right, flipping about half of them on their side. Please contact JAR Systems for additional assistance.

5: Plug the charger into the power strip. For best results, bundle any excess cable length if it is not already (H).

6: **OPTIONAL** - Replace the security screw in the center of the shelf to prevent adapters from being removed or tampered with (I).



Warnings

- Power down all devices prior to connecting them to the hub for charging.
- Keep away from moisture and harsh chemicals. Do not place any liquids near the charging cart.
- Any electrical equipment must be used by an adult or with adult supervision.
- Do not connect unsupported items to the charging cart or use for any purpose other than its intended use.
- Do not attempt to obstruct any ventilation openings or dismantle, open, or modify the system in any way.
- Do not sit or stand on the cart or charging hubs.
- Do not use an extension cable or daisy-chain to any other devices.
- Not intended for operation at altitudes greater than 2000 m or 6561 ft above sea level and should not be operated in extreme temperatures. For indoor use only.

Disclaimer

Failure to read, thoroughly understand, and follow all instructions can result in serious personal injury, damage to equipment, or voiding of factory warranty. Since the use of this information, the equipment connected, and the conditions by which any JAR Systems product is used is beyond the control of JAR Systems, it is the obligation of the owner and/or user to determine the correct and safe use of any equipment and product. To the extent that the law permits, any liability which may be incurred as a result of the use or future use of a product manufactured or sold by JAR Systems is limited to the cost of repairing or replacing the failed product or component at the discretion of JAR Systems either within, or outside of warranty periods, and does not extend to any loss or damage which may be caused as a consequence of misuse or failure of the equipment, product or the information contained herein. JAR Systems shall not in any event be liable for economic loss of profits, indirect, special, bodily injuries or consequential damages. Specifications and images are for illustration purposes only. Final product may differ and is subject to change without notice.

JAR SYSTEMS

Warranty

This product comes with a warranty that covers any defects in material or workmanship and extends to the original consumer of the product only. JAR Systems, LLC will replace the product with a new or refurbished product, repair the product, send replacement parts, or refund the purchase price of the product, at JAR Systems, LLC's discretion. This warranty does not cover accidental damage, unreasonable use, neglect, tampering or other causes not arising from defects in material or workmanship.

Any implied warranties last only as long as the warranty periods listed above except where state law does not allow limitations on how long an implied warranty lasts. This includes but is not limited to the implied warranties of merchantability and fitness. JAR Systems, LLC's responsibility is limited to the actions listed above and nothing else.

This warranty does not cover, and JAR Systems, LLC will not be responsible for, any damages due to loss of use of the product, or any other costs or expenses incurred by you or anyone else who uses the product, whether due to defects, breach of contract, negligence, strict liability or otherwise. JAR Systems is not liable for any indirect, special, incidental or consequential damages related to the product or this warranty. Some states do not allow exclusions or limitations on consequential or incidental damages, so these limitations or exclusions may not apply.

This warranty gives you specific legal rights and you may also have other rights that vary from state to state. This warranty is governed by the laws of Florida, excluding its conflict of laws principles, unless your state requires that its law be used.

Contact JAR Systems for information on the length of warranty on your product(s).



Explore more options for USB-C Charging!

Learn about ways to charge devices in growing technology landscapes. Contact a JAR Systems representative at 866.393.4202 or visit:

JAR-Systems.com/Products