

# Ultra-Light Intelligent Service Plus Carts

## MD-51XX-SP



MD-5150-SP



MD-5135-SP

## Assembly and Configuration Manual























---

### Version E

For a copy of the most up-to-date manual, please contact a JAR Systems representative or visit:

[www.JAR-Systems.com/Support](http://www.JAR-Systems.com/Support)

# Cart Assembly Instructions

Components				
 x1	 x1	 x1	 x1	
 x1	 x1	 x2	 x1	
 x2	 x1	 x2	 x42 or x32	 x4
 (A1) x24	 (B2) x16	 (C3) x12	 (D4) x12	
 (E5) x4	 (F6)	 (G7, H8)	 (I9)	 Hasp Kit (MD-5150 only)

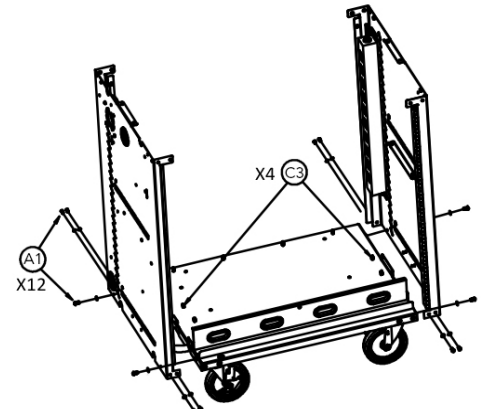

**1:** Attach both side panels to the bottom of the cart. Position the studs in the side panel into the tabs in the base and hand tighten 2 nuts (C3) on each side with the 8mm wrench (F6). **Do not use a power tool to tighten nuts on any step.** Use 3 screws and 3 washers (A1) in each corner.

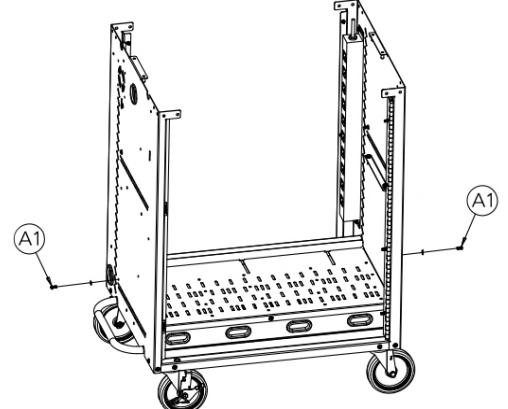

**2:** Install the tray lid for the bottom shelf using one screw and one washer (A1) on each side.

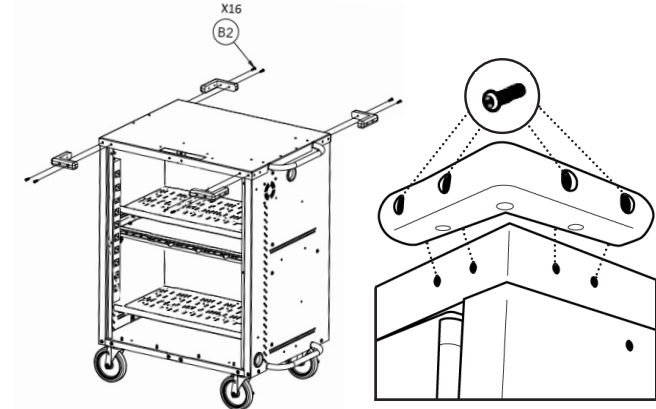

**6:** Locate the holes on each corner of the top panel for the gray rubber bumpers. With the included drill tap bit (F6), drill through the holes to ensure the screw goes in securely. Place a bumper to each corner of the cart's top and secure in place using 4 screws (B2). The bumpers have a top and bottom side to them. The side with the circle marks should be facing down. To allow for the cart to be squared in a later step, **do not fully tighten the screws during this step.**

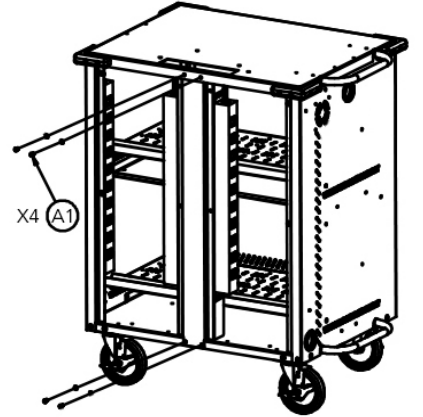

**7:** Attach the rear center support to the top and bottom panels of the cart using 2 screws with 2 washers (A1) on each end. To allow for the cart to be squared in a later step, **do not fully tighten the screws during this step.**

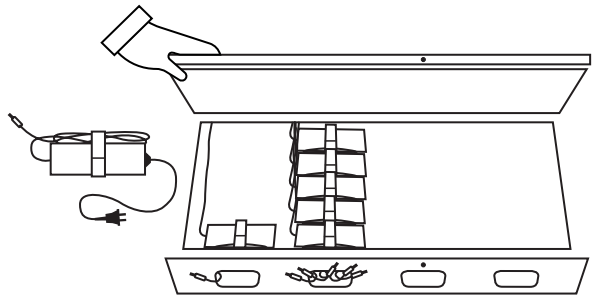

**8: OPTIONAL-** If installing the charging cables at the same time as the cart assembly, installing after step 7 provides the most unimpeded workflow. **See page 6 for cable management instructions.** Don't worry, you can still easily install the charging cables after the cart is fully assembled if needed.

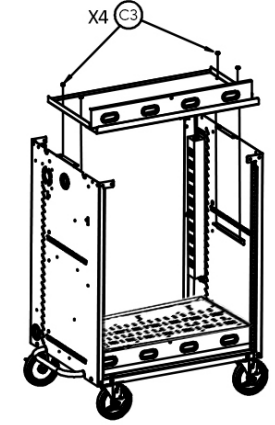

**3:** Install the upper tray. Position over the studs in the side panels and hand tighten 4 nuts (C3) with the 8mm box wrench (F6).

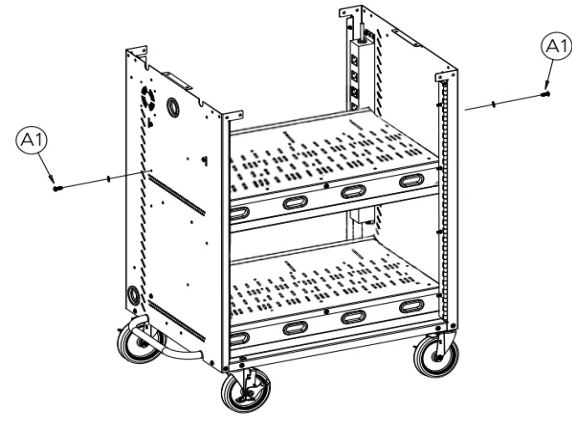

**4:** Install the tray lid for the top shelf using one screw and one washer (A1) on each side.

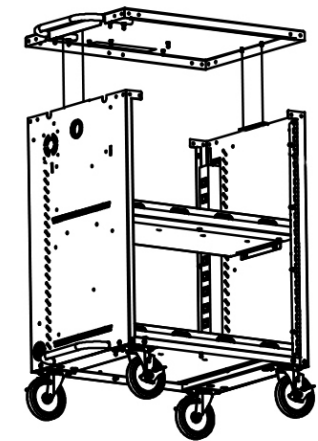

**5:** Align the top panel of the cart with the side panels and position it in place. **Do not secure the top during this step.** The top will be secured in step 19.

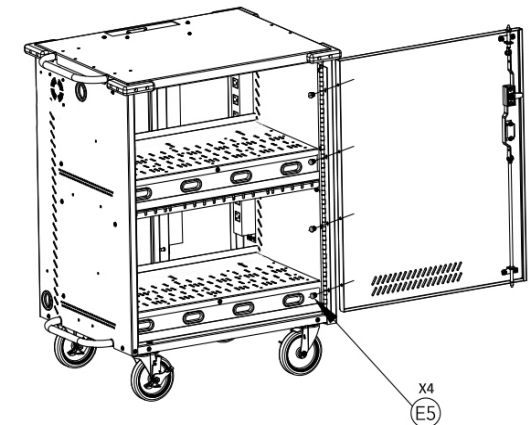

**9:** Attach the door to the hinge on the right side panel with 4 screws and 4 washers (E5). Insert the Torx key (F6) through one of the screw holes on the hinge and door to help hold it in place. Remove the key once the first 3 screws are inserted. Insert the 4th screw while holding the door. Check that the door is square and opens/closes without striking the frame.

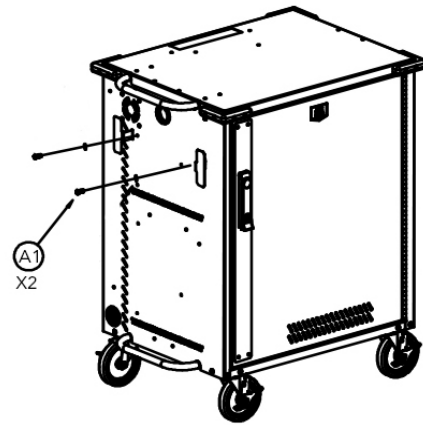

**10:** Attach the brackets for wrapping the power cable to the cart's left side panel using 1 screw and washer (A1) on each.

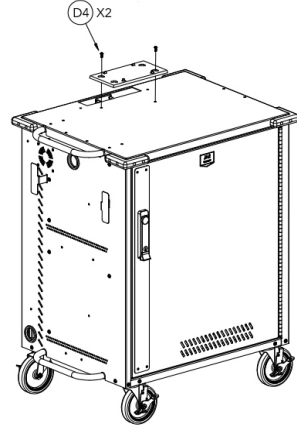

**11:** Attach the mounting plate for the Intelligent Charging System to the top of the cart using 2 screws with washers (D4).

# Cart Assembly Instructions

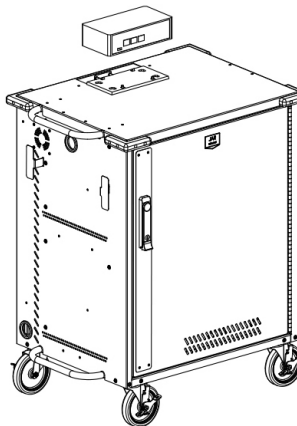

**12:** Align the openings on the bottom of the Intelligent Charging System with the clips on the mounting bracket and apply pressure to clip it into place.

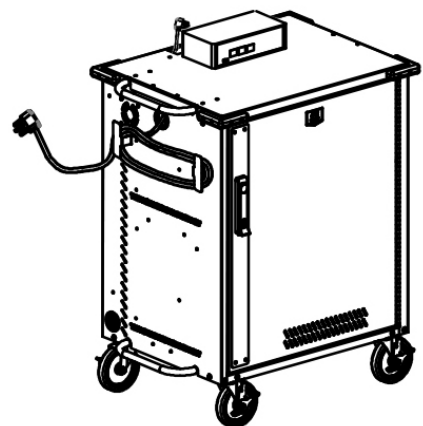

**13:** Find the plug end of the main power cable. Route it down the opening in the top of the cart and out of the opening on the left side of the cart. Plug the socket end of the cable into the back of the Intelligent Charging System. Pull any excess cable out of the cart and wrap it around the brackets installed in step 9.

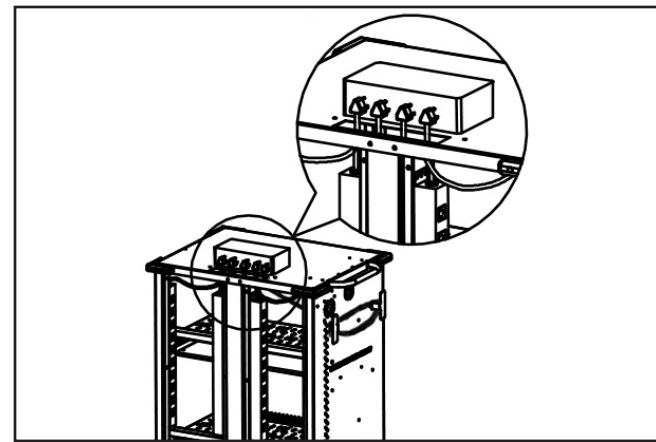

**14:** Route the 4 power strip cables through the hole in the top of the cart. Looking at the cart from the back side, plug the power strip that is farthest to the right in the cart into the outlet in the back of the Intelligent Charging System that is labeled "1" and repeat with the following cables in order.

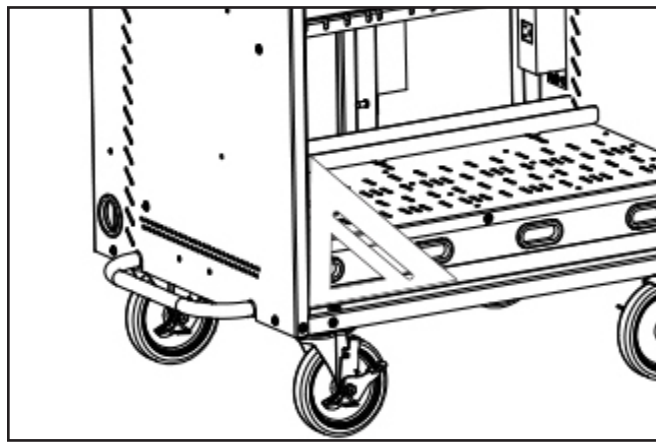

**18:** Check the cart square by placing a rafter square in the bottom corner of the door frame or use the door as a guide. Check that the gap around the door edges to make sure that it is even and the door has smooth operation. Fully tighten screws on the front and rear sides of the cart.

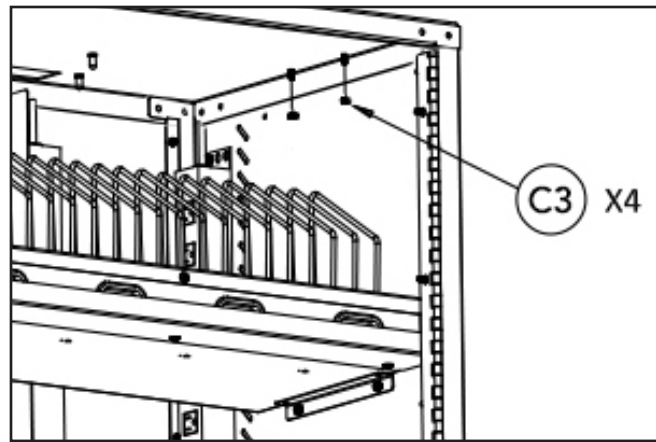

**19:** Secure the top of the cart using 4 nuts (C3).

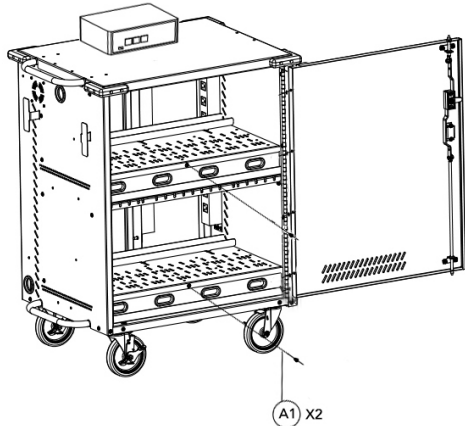

**20:** If the charging cables **were not** installed in step 8, install the cable management clips (G7, H8) underneath each tray for later use. **See page 6 for further instructions on cable clips.** Secure each tray lid shut with one short screw with a silver washer (A1).

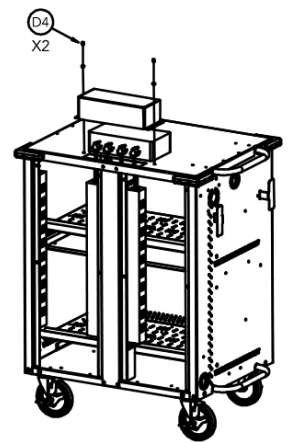

**15:** Install the cable cover over the back of the Intelligent Charging System using 2 screws with washers (D4). Use the Torx key (F6) to tighten the screws. **Do not use a power tool** as it will leave scratches on the cable cover.

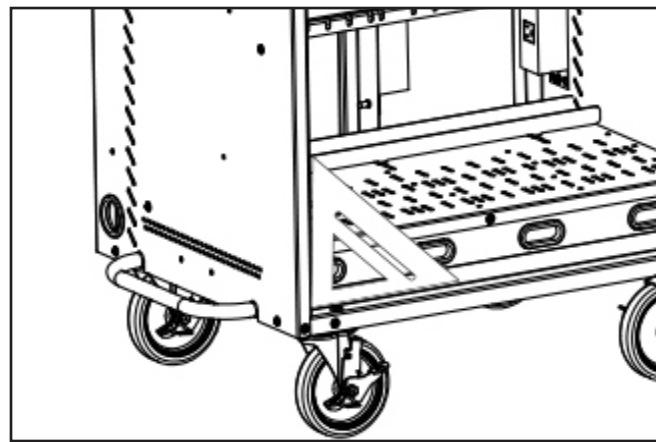

**16:** Check the cart square by placing a rafter square in the bottom corner of the door frame or use the door as a guide. Check that the gap around the door edges to make sure that it is even and the door has smooth operation. Fully tighten screws on the left and right sides of the cart.

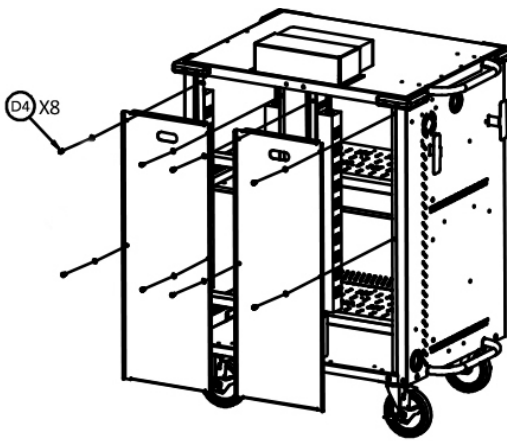

**17:** Attach each of the rear access panels to the cart using 4 short screws with plastic washers (D4). To allow for the cart to be squared in a later step, **do not fully tighten the screws during this step. Do not use a power tool.**

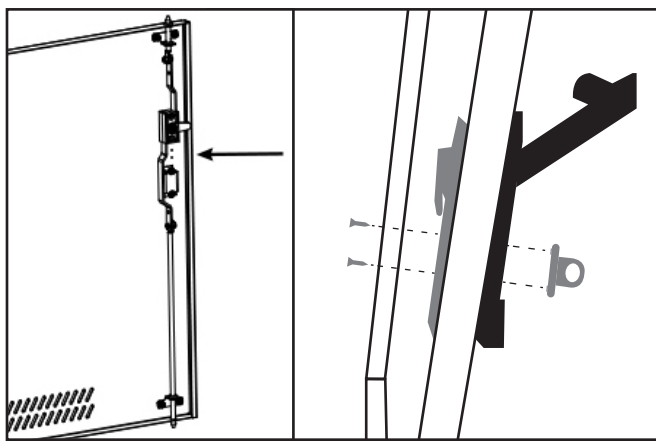

**21: MD-5150 Model Only-** Locate the two screw holes on the inside of the front door between the locking hardware. With the swing handle in the open position, align the hasp hardware with the two screw holes on the front side of the handle. Insert the two included screws from the inside of the door to secure. **Padlocks are not included.**

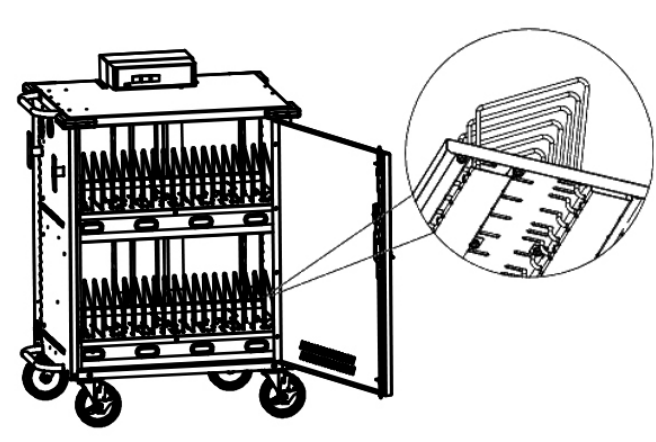

**22:** Insert the metal device dividers into the trays. **See page 8 for instructions on inserting the dividers.**



**23:** To check that the charging system is properly connected, plug the cart into a working outlet. The Intelligent Charging System should make a brief "beep" sound, the firmware version should display in the LCD window, and a blue light will illuminate to indicate the system is receiving power.



# Installing Charging Cables and Adapters

**1:** Remove the security screw using the provided Torx key (F6) from the center of the shelf **(A)** and temporarily place it in the side of the cart **(B)** to hold the tray open during the wiring process.

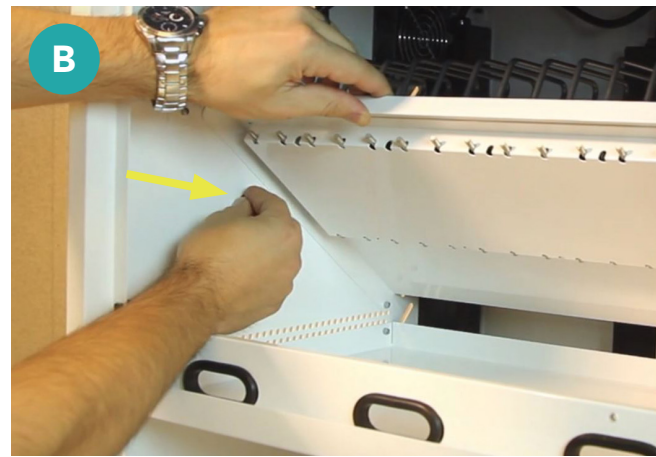

**2:** Determine the length of cable that is needed to reach from inside the tray to the devices **(C)**.

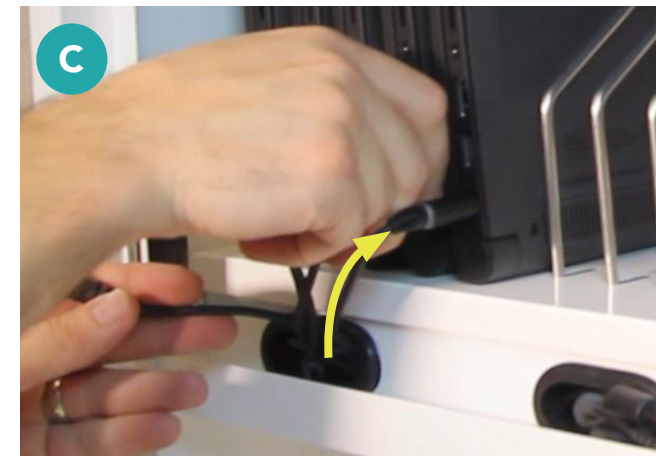

**3:** Determine the best method of arranging the cables that come with your device (figures **D, E, F** below). Use of cable clips (G7, H8) is optional for any configuration.

**AC ADAPTERS FRONT TO BACK**  
Best for some wider adapters.

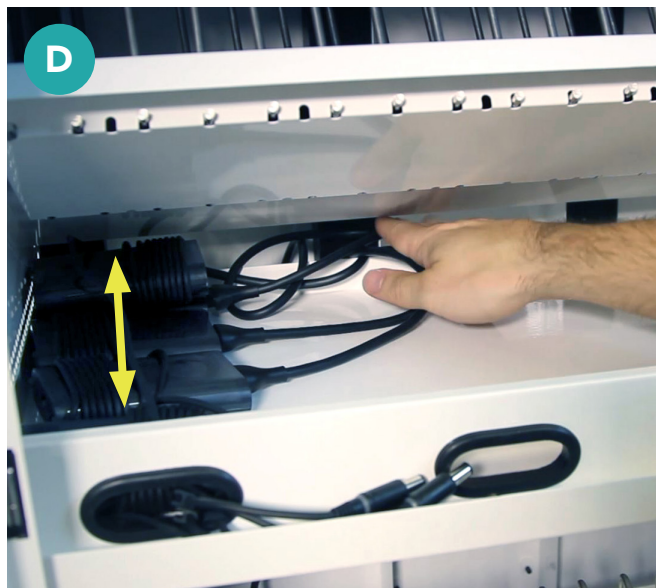

**AC ADAPTERS LEFT TO RIGHT**  
Best for some narrower adapters.

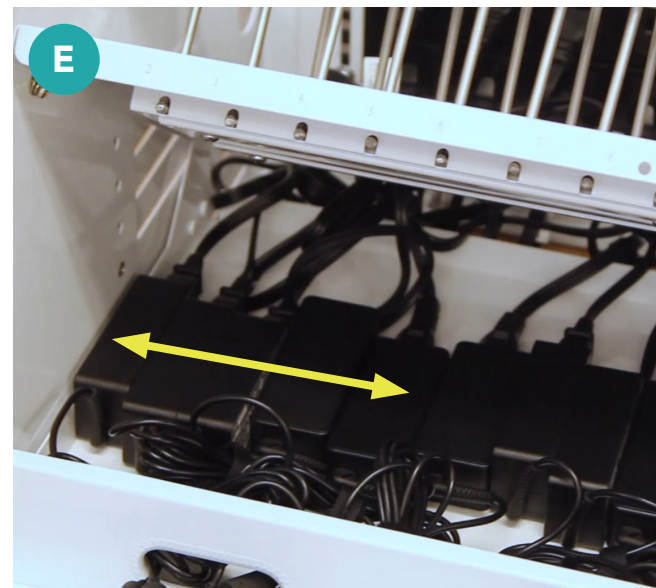

**TABLET (NO AC ADAPTER)**  
Use provided clips beneath shelf to secure cables in groups of 5-6.

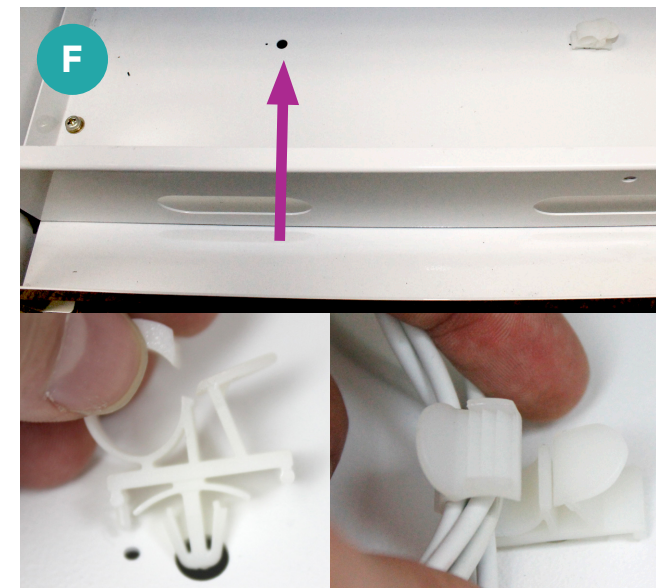

**4:** Arrange adapters in decided configuration, leaving just enough cable length sticking out of the port to plug in the devices.

**TIPS:**  
Adapters can often be installed as they come bundled in the box. For example, the adapter in figure **(G)** comes with the cable wrapped around the adapter and it works out nicely when installed in that condition. If the cables are not bundled at all, twist ties or Velcro ties may be helpful.

If the devices have particularly large AC adapters (approximately 5" x 2" x 1.25") the adapters will fit more snugly in the tray. In this case it may be best to arrange the majority of the adapters as far back in the tray as possible from left to right, flipping about half of them on their side. Please contact JAR Systems for additional assistance.



**5:** Plug the charger into the power strip. For best results, bundle any excess cable length if it is not already **(H)**.



**6: OPTIONAL-** Replace the security screw in the center of the shelf to prevent adapters from being removed or tampered with **(I)**.



**EXAMPLE**



# Installing Device Bays

Service Plus carts feature adjustable device bays with multiple configuration options. This means that not every slot in the tray will have a divider in it and there may be extra, unused dividers at the end of the assembly process depending on which hole pattern is used. Use the guides below to determine which hole pattern to use.

To install the dividers, simply place the tall side of the divider into the rear slot first, then push in and down to get the other side into the front slot.



## MD-5150-SP CART

### 40 DEVICE PATTERN

Best for devices up to 1" wide.

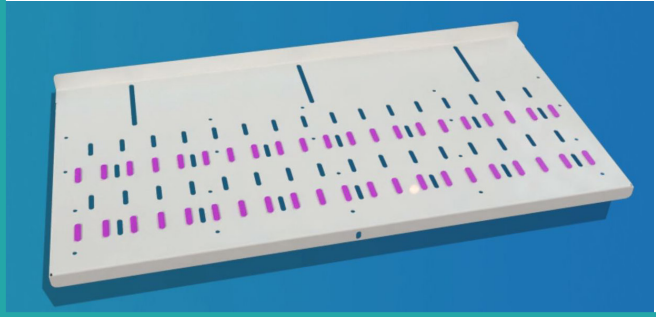

### 30 DEVICE PATTERN

Best for devices up to 1.25" wide.

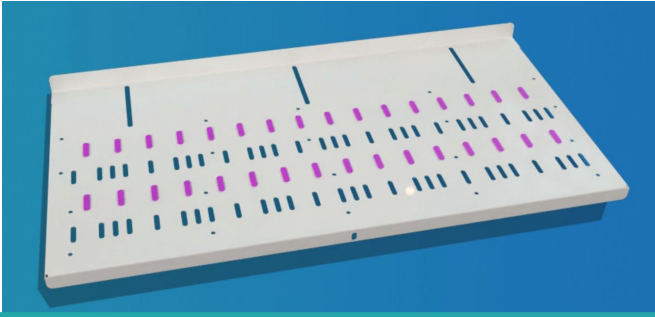

### 28 DEVICE PATTERN

Best for devices up to 1.5" wide.

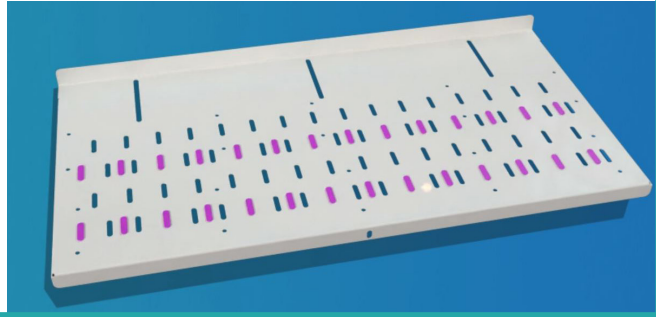

## MD-5135-SP CART

### 30 DEVICE PATTERN

Best for devices up to 1" wide.

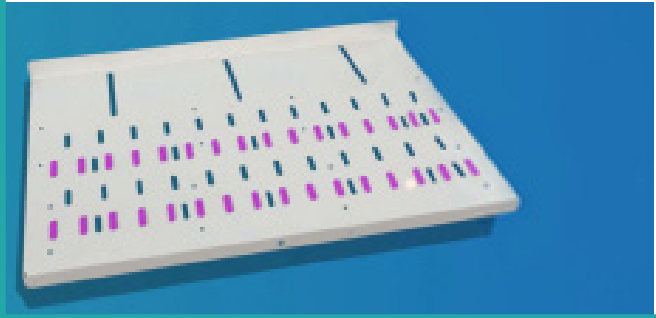

### 22 DEVICE PATTERN

Best for devices up to 1.25" wide.

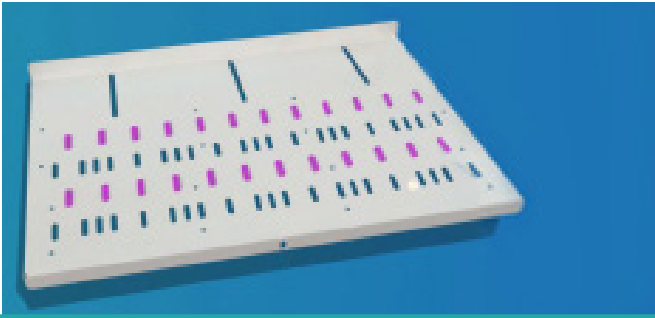

### 20 DEVICE PATTERN

Best for devices up to 1.5" wide.

